

Hyskore®

Dangerous Game® Machine Rest

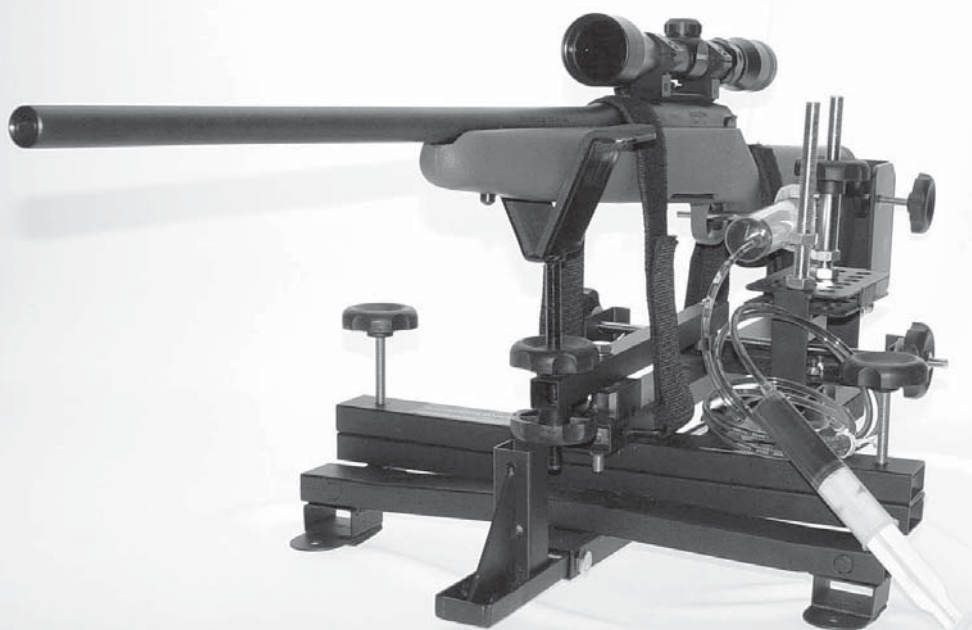

Always Use Appropriate Eye & Ear Protection When Using This Device !

This excellent rifle rest is designed for the serious shooter or hand loader. It will accommodate everything from a .223 to a .416 Rigby (including .50BMG) without damage to your weapon or to your shoulder. All you need to do is pay attention to the instructions and observe all the standard safety procedures.

Before using this product, it is imperative that you read the instructions. The **Dangerous Game® Machine Rest** is supplied with 3 different compression dampers. Each one is calibrated to a specific recoil range. Using the incorrect damper could result in injury or damage to your weapon and / or the rest.

It is important to use a rock solid bench. The **Dangerous Game® Machine Rest** is capable of impressive repeatability. However, if your bench moves, your group will open.

That being said, follow the simple assembly instructions and enjoy this fine shooting accessory.

In the course of shipping and packing, parts may end up missing or damaged-
call us at 631.673.5975. 8:30 a.m. - 5:00 p.m. Eastern Time. We will promptly send replacements.

Introduction

READ THIS ENTIRE MANUAL BEFORE USING THE REST!

The purpose of the **Dangerous Game® Machine Rest** is to allow the shooter to fire the weapon without having to contend with recoil or any human contact and related motion contamination. By calibrating the weapon and/or ammunition in this manner the shooter is able to obtain a clear picture of weapon accuracy.

WARNING !!

- A. The **Dangerous Game® Machine Rest** will accommodate *most factory* rifle / ammunition combinations that are in the hands of American shooters up to and including, powerful .416 Rigby factory loads. Always calculate your recoil and use the correct damper. NEVER exceed a Damper's upper limit or use a damper that has insufficient compression.
- B. Vibration and motion caused by shooting may cause knobs and adjustments to loosen. **Check them after every 3rd shot.** Pay special attention to the knobs that hold the gas springs in place.
- C. Every 3rd Shot make sure the 2 velcro straps are properly secured.

READ THIS CAREFULLY

The **Dangerous Game® Machine Rest** is designed and constructed to operate consistently and safely within certain limits, i.e., *do not use gun/ammunition combinations that will exceed the recoil range for the compression damper being used.* The following chart is a *general* guideline for recoil expectations. If you exceed the maximum recoil for a specific damper, you can expect several very bad things to happen as the travel of the damper may be exhausted and the gun carrier may "bottom-out".

First: Expect damage to the gun stock as the inertia of the barrel / action will now be absorbed by those components. **Second:** For the same reason you can expect the action / and barrel to separate from the bedding. **Third:** You may damage the structural components of the rest. Always calculate the maximum recoil for your gun and Ammunition combination and use the appropriate compression damper. NEVER exceed a Damper's upper limit. Conversely a damper with too much compression for the gun / ammunition combination can result in similar consequences.

If you're not impressed with damage to your weapon and your rest, over loading the device by using a light gun and/or too potent a loading for the damper has the potential to result in serious injury. Use common sense and observe, all firearms safety procedures. Never use this rest to fire any weapon that is not in "as new" condition or certified safe by a competent gunsmith.

There are multiple sets of mounting holes in the bracket that secures the trigger release to the rest. Choose the set that is optimum for the gun(s) that you will use. It may be necessary to place the (unloaded) gun in the rest to determine the best location.

Never exceed the Gun Manufacturer's maximum recommended loading for any ammunition.

Repeat: if you do something dumb, bad things can happen. The chart is only a general guideline. For more detailed recoil data (as of this writing) there are several good websites that you can reference:

- | | |
|---|---|
| 1. www.real-guns.com | 4. www.handleads.com |
| 2. www.zvis.com | 5. www.rfgc.org/reload |
| 3. www.chuckhawks.com/recoil | 6. www.siskguns.com |

or go to our website (www.hyskore.com) click on the image of the **Dangerous Game® Machine Rest** then click on the link to the recoil calculator.

The recoil that you feel is a function of the action-reaction created as the bullet moves forward in the barrel and, shortly thereafter, gas exiting the muzzle (Rocket Effect). Therefore, *the quantity of propellant in addition to* gun weight, bullet weight and muzzle velocity is an important factor in determining recoil. Make certain that this is part of your calculation. Calculate your recoil carefully and **DO NOT EXCEED THE LIMITS OF THE COMPRESSION DAMPER YOU ARE USING !**

Approximate Recoil in FT LBS.

Cartridge	Bullet Weight	Muzzle Velocity	7.0 LB Gun	8.0 LB Gun	9.0 LB Gun	Damper Size
223 Rem	52	3417	5	4	3	Mild # 1 FT / Lbs. Min: 3 Max: 20
22-250 Rem	52	3800	6	5	5	
243 Winchester	100	2700	7	8	10	
7.62mm x 39mm	125	2160	7	6	5	
30 - 30 Winchester	150	1950	8	7	6	
25 -06 Rem	85	3400	14	13	11	
270 Winchester	130	2790	16	14	12	
270 WSM	160	2540	18	16	14	
308 Win	150	2750	18	16	14	
8mm Mauser	150	2695	18	16	14	
308 Win	200	2350	20	18	16	
7mm Rem Mag	160	2675	21	19	17	Medium # 2 FT / Lbs. Min: 20 Max: 50
30 - 06 SPFLD	150	2850	23	20	18	
8mm Mauser	150	2434	24	21	18	
30 - 06 SPFLD	200	2600	29	25	22	
300 Win Mag	150	3210	33	29	26	
338 Win Mag	160	3098	37	33	29	
300 Win Mag	200	2850	38	33	29	
300 WBY Mag	150	3424	39	34	30	
338 Win Mag	270	2930	39	34	30	
300 Rem UM	150	3670	45	40	35	
300 WBY Mag	200	3014	45	39	35	
338 Lapua	275	2478	45	40	35	
12 GA	525 (Slug)	1522	46	38	34	
300 Rem UM	200	3130	52	45	40	
375 H & H	300	2700	55	48	42	
338 RUM	275	2700	63	55	49	Heavy # 3 FT / Lb. Min: 50 Max: 85
375 RUM	300	2690	67	58	52	
416 Rem Mag	400	2450	83	72	65	
378 Weatherby	300	2850	89	78	69	
416 Rigby	400	2380	89	78	69	
458 Winchester Mag	500	2200	95	83	74	
416 Weatherby	400	2570	102	90	80	

Warning Choose the Appropriate Damper: Using the Mild # 1 Damper for a high recoil gun may exhaust all of the travel in the damper and cause the **Dangerous Game® Machine Rest** to "bottom out." This could result in damage to the **Dangerous Game® Machine Rest** and/or damage to the weapon, specifically the stock and the bedding. In extreme cases this type of over loading could result in personal injury. Once again, Vibration and motion caused by shooting may cause knobs, adjustments and straps to loosen. Check them after every 3rd shot. Also make certain that your bench is secure. If the bench shifts, it will be impossible to hold a tight group. Pay special attention to the knobs that hold the gas springs in place.

Do Not use gun / ammunition combinations indicated in Bold Type.

Use of the Heavy # 3 Damper should be limited to high recoil guns that recoil in the 50 to 85 FT/Lbs. range. There is the possibility that Mild & Medium recoiling guns will sustain damage to stocks, bedding and recoil lugs if you use a damper with excessive resistance.

The **Dangerous Game® Machine Rest** is primarily designed for center fire rifles. If you use it for a rim fire weapon, extensive use could cause damage to the bedding, stock and recoil lugs. Even the Mild Damper offers more resistance than a .22 long rifle (about .25 FT/Lbs. Recoil in a 6 Lb gun).

The **Dangerous Game® Machine Rest** will successfully accommodate a much wider range of cartridges than listed on the chart. But only if (and we repeat - ONLY IF) you have performed the recoil calculations and determined that the recoil is within the range of one of the dampers. Not to be repetitive but, if you exceed the recommended limits for any gun/damper combination, bad things can happen, not only can you damage the rest and/or your weapon but the end result could be personal injury.

Assembly Instructions



A) Fit the vise to the carrier using the 3 bolts & nuts. Tighten to 14 - 15 FT / Lbs.of torque.

Nomenclature

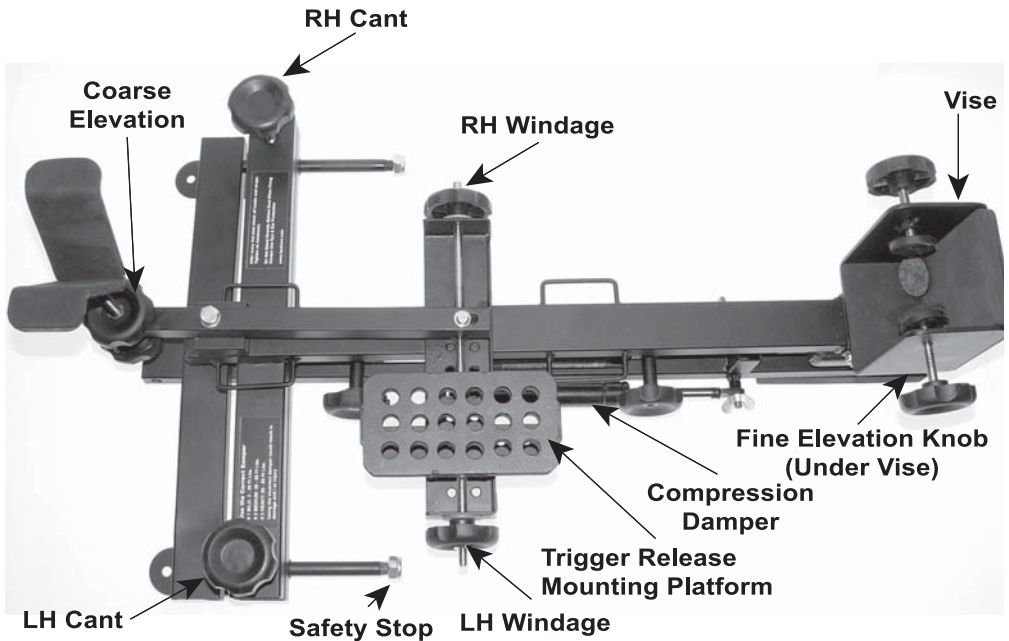

Before proceeding make both a visual and mechanical examination to make sure your weapon is unloaded.

Instructions:

1. The very first thing to do is select and install the correct damper. If you change guns make sure the correct damper is installed. **Too much or too little damping can result in injury or damage.**

2. Place the rest on a solid, level, flat surface. Pointing down range!

3. Extend and invert the bench grip, fix it to the rest with the supplied wing nut and bolt. **Figure # 1**

4. **Important:** The arm of the bench grip and the base of the rest are drilled with 1/4" holes use them to securely anchor the rest. For a concrete bench you may want to anchor the rest to a piece of 3/4" plywood then clamp that to the bench.

NOTE: Before you firmly anchor the rest check your elevation. If it is too high, it may be necessary to elevate the rear end of the rest with a wood block.

5. Set the gun in place. Use 1 or 2 foam pads to protect the stock.

Figure #2 Clamp the butt in the Vise keeping it centered, tighten the vise using just enough pressure to secure the weapon. Do not over tighten. **Figure # 2** If your gun has a monte carlo stock make certain that the vise clamp is at least 3/4" behind the cheek piece. This will prevent the vise face from damaging the raised part of the stock. (If necessary) A wood spacer can be used to move the gun slightly forward.

6. Set the elevation of the "V" Notch Support. *Do this before you secure the weapon with the velcro straps.*

7. Using the rear Velcro strap *snugly* fasten the gun into place.

Figure # 3

8. Secure the forward strap allowing for the barrel to rise no more than 1/4". If your barrel is free floating, do not over tighten.

9. Position the trigger release on the mounting platform. **Figure # 4.**

10. Use the fine elevation and windage knobs to zero in. Use the left and right hand knobs to adjust cant.

11. You are now ready to fire.

12. After your first 3 - 4 shots the gun and rest should be firmly seated. Check and adjust your sight picture. - Make any appropriate adjustments to the vise and securing straps. Check to make sure knobs are tight. If you change the elevation, the straps may need to be reset.

13. After each shot especially when using the #1 Mild damper, it may be necessary to push forward on the back of the vise to return to 100% battery.

Important Safety Recommendations:

You will have a tendency to look through the sight when firing -DO NOT DO THIS!!

1. **Do not put your eye or face or hand (or any other body part) behind the sight, scope or anywhere else near the gun. A 30-06 will generate 1.5 - 2.0" of very rapid rearward travel. If your in the way, you will get hurt.**

2. Always wear approved eye and ear protection.

3. Velcro does not last forever. When it shows signs of wear or degradation in grip, replace it.

4. **Do not drop!** All parts are factory aligned then welded into place. If you bend something it may not be repairable or replaceable. Using the rest in damaged condition could result in injury.

5. **Load one round at a time.** This way the gun will have uniform weight every time it is fired.

6. Do not use high capacity magazines as there may not be sufficient clearance under the gun.

7. Always anchor the bench grip arm to the bench. A 1/4" lag bolt works the best.

Maintenance:

1. All the non-contact metal parts are powder coated. This is a durable finish. However, if you don't dry it off after it gets wet, eventually it will rust.

2. Lubricate all points where there is contact between moving parts. Acid Free Machine Oil works well.

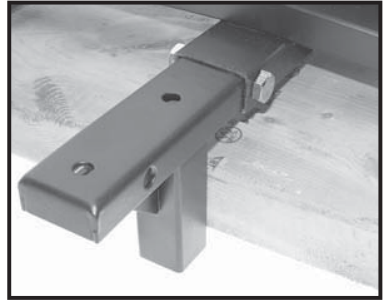

Figure # 1

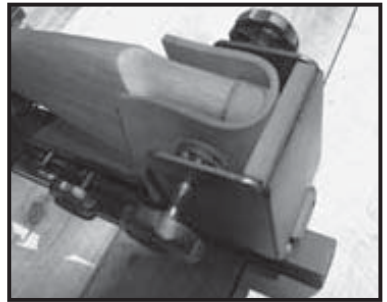

Figure # 2

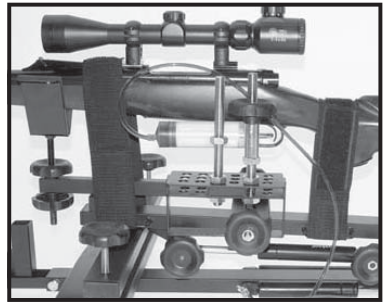
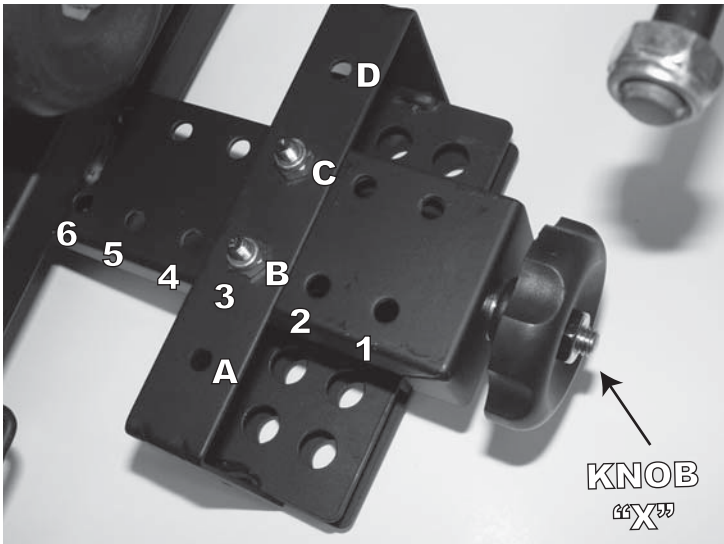

Figure # 3



Figure # 4

How To Mount the Trigger Release Bracket



The Trigger Release Mounting Bracket can be mounted in 18 different positions. A good starting point is to locate the bracket as indicated using holes "B" & "C" and Row 3. To install, remove knob "X" by first backing off the retaining nut. Locate the bracket as shown and replace knob "X". Use the supplied screws and nuts. Tighten to 6 - 7 FT / Lbs. of torque. Whether or not the knob is in place when you fasten the bracket is matter of personal preference.

Hydraulic Trigger Release

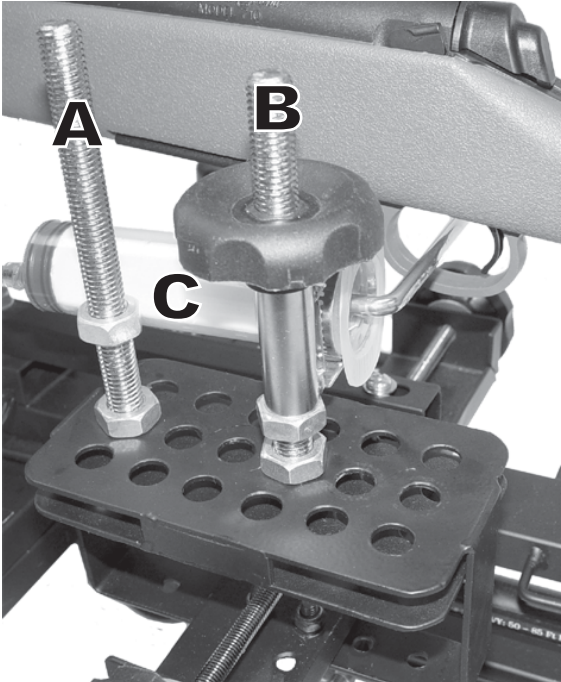

Installation and utilization of this device will allow you to fire the weapon without any human induced motion contamination.

Setting up the Trigger Release:

- 1) Depress the plunger on the slave cylinder "C".
- 2) Insert the Trigger push rod through the Trigger Guard in front of the Trigger.
- 3) Insert Bolt "B" through the mounting tube on the trigger release bracket. Put it through any set of holes that align properly and fix it into place, locating the nuts & knobs as shown. Generally hand tight will be sufficient. If you use a wrench do not over tighten.
- 4) Locate Bolt "A" as shown, if necessary use Nut "C". The purpose of this part is to keep the slave cylinder parallel to the gun. This way maximum pressure can be applied directly to the Trigger.

ADJUSTMENTS

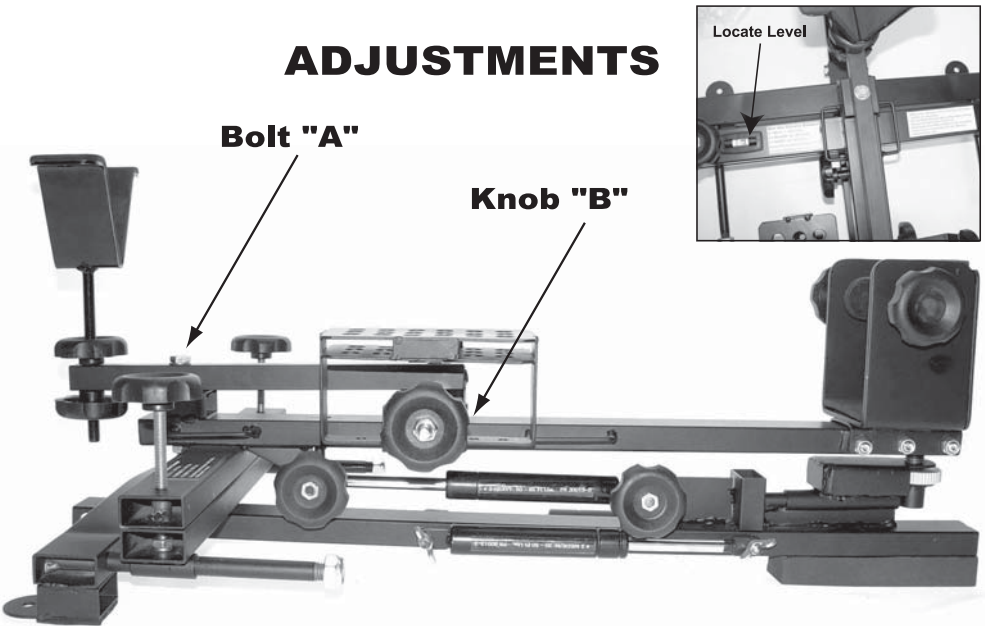

Sometimes due to shipping and handling small amounts of play may develop.

- 1) Check all fasteners in steps # 1 and # 2 of the instructions for proper tightness.
- 2) Bolt "A" should be snug (no play) but not too tight. As it must allow the windage adjustment to pivot.
- 3) Back off the retaining nut at Knob "B". Tighten the knob to within 0.5mm +/- (the thickness of a business card) of the bracket, then secure with the nut.

ADJUSTING THE REAR GUIDE

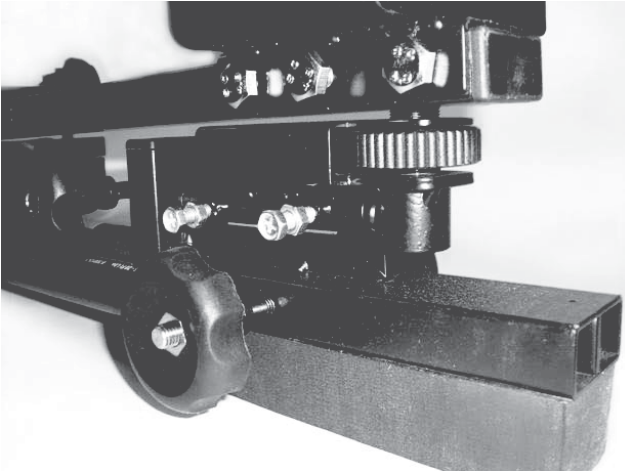

The rear guide and the guide rod that it rides on are both round. Even though there is some clearance between them, gravity insures that they self center after each shot. If you feel that it is necessary to remove the free space, install the (M6 x 16mm x 1.0) bolts and jam nuts as shown. Finger tighten then back off 1/2 turn and use the jam nut to lock into position.

Notice: If you remove too much free play binding may result. This could cause damage to the stock and bedding of your weapon-with this in mind, after making an adjustment, place the rest on its tail end and push on the upper carriage to confirm smooth cycling without binding.

Hyskore®

Suggestions For Building A Shooting Bench Platform

For the 30013 Dangerous Game® Rest, 30003 Precision Rifle Rest, 30080 Ten Ring® Shooting Rest or 30088 DLX Precision Shooting Rest

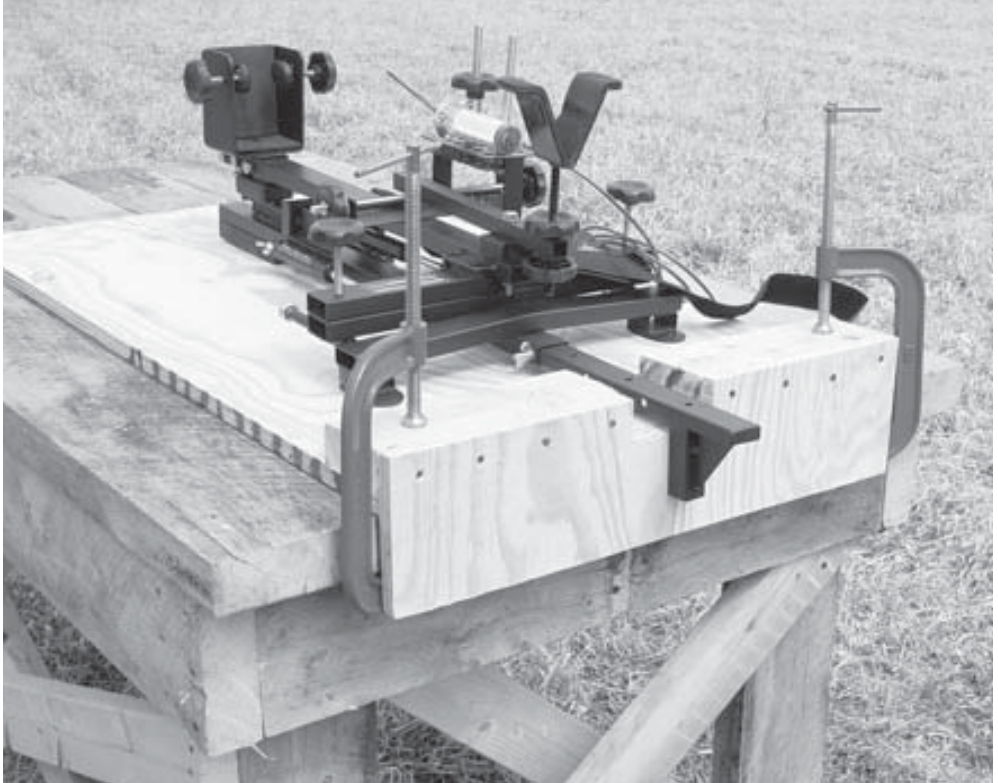

Both of the above captioned rifle rests must be secured to a bench. When there is a concrete bench or a range that doesn't allow shooters to screw anything to their benches it is necessary to mount your rest to a platform that can be fixed to the bench using "C" Clamps.

Suggested Bill of Materials: For Constructing a Bench Platform

These components can be purchased at any big box home improvement retailer.

Qty.	Description
1 -	24" x 48" x 3/4" Plywood
2 -	2" x 4" x 8" wood block
2 -	6" or 8" stair angles (These are heavy duty 90° angle braces. At Lowes or Home Depot they can be found in the lumber area with the joist hangers.)
1 -	Wood Glue (The exterior type is the best)
2 -	5/16" x 3/4" Sheet Metal Screws
1 -	5/16" x 1 1/2" (or 2") Sheet Metal Screw
16-20 -	2" Drywall Screws
2 or 4 -	"C" Clamps (Size will depend on the thickness of the bench)

STEP 1

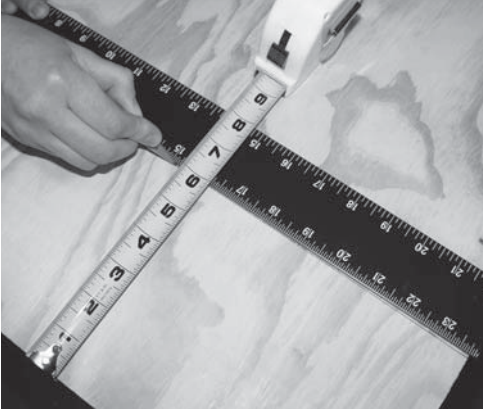

Using a 24" x 48" x 3/4" piece of Plywood cut a 6" x 24" section of the plywood for the front edge brace.

STEP 2



Cut 2 - 10" Pieces of 2 x 4. Glue and screw them to the Plywood base.

STEP 3

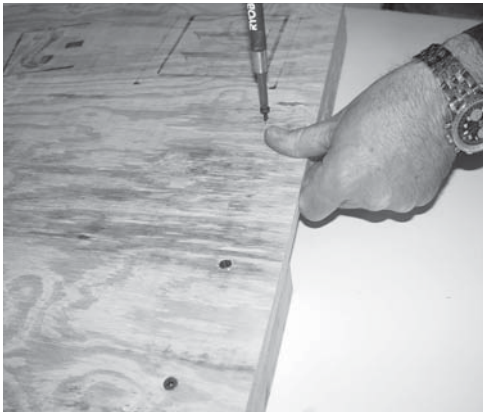

Use 2" screws to secure the 2" x 4" x 10" blocks from the Underside.

STEP 4

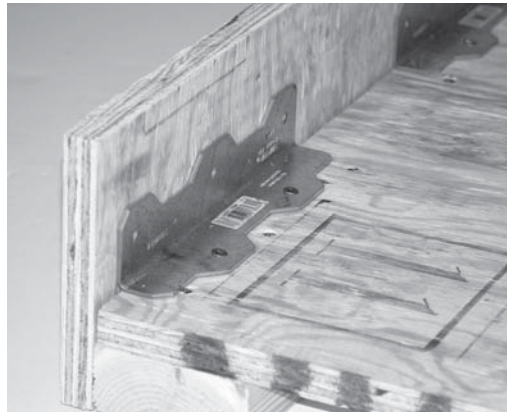

Glue & Screw (w/ 2" screws) the 6" x 24" piece of plywood across the front as shown. Use 2" x 6" (or 8") stair angles for reinforcement. Secure with screws.

STEP 5

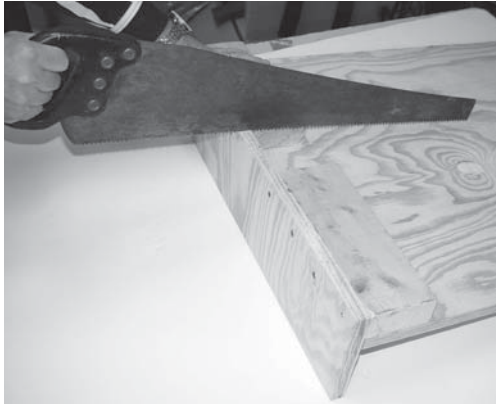

Notch the front brace so that the edge of the notch is flush with the surface of the plywood base. This can be done either before or after it is fixed in place.

STEP 6

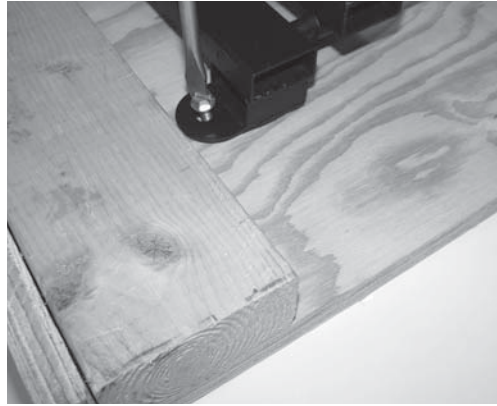

Use 2 - 5/16" x 3/4" sheet metal screws to anchor the left & right sides of the rest. You may find it necessary to stack several flat washers between the flange on the rest and the plywood.

STEP 7

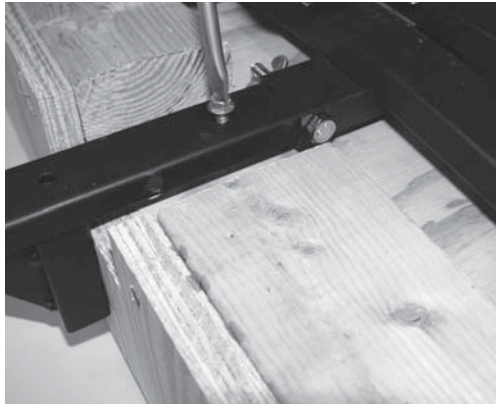

Use 1 - 5/16" x 1 1/2" (or 2") sheet metal screw to anchor the bench grip arm.

STEP 8

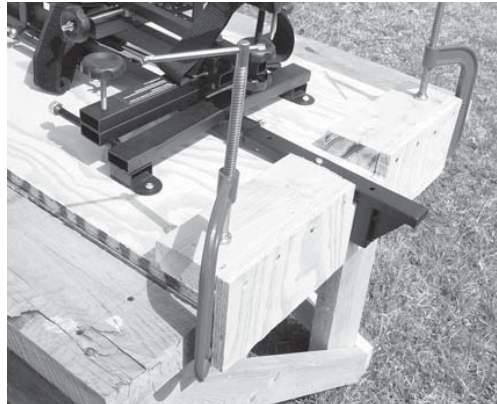

Use 2 or 4 - "C" Clamps to anchor the completed set-up to the bench.

CALCULATING RECOIL

There are two ways to do this.

- A. The easy way - go to one of the websites listed in this pamphlet or go to one of the links listed on our website: www.hyskore.com
- B. If you like playing with numbers, use the following formula. While Isaac Newton or Albert Einstein might take us to task for being off by 2 or 3 %, this will get you into the ballpark. We have divided the process into 2 steps. First, calculate the recoil velocity then use this information to calculate the recoil energy in ft/lbs.

Legend:

- PW - Weight of powder charge
- BW - Weight of bullet (grams)
- MV - Muzzle Velocity
- GW - Weight of loaded gun/w scope
- RV - Recoil Velocity
- RE - Recoil Energy

$$1. RV = \frac{[(1.75 \times PW) + BW] \times MV}{7,000 \times GW}$$

Run the calculation like this:

- A. Multiply the weight of the powder charge PW x 1.75
- B. Add the bullet weight (BW) to this number (result from A)
- C. Multiply this number (result from B) by the bullet velocity (MV) - Hold this number aside
- D. Multiple the weight of the gun (GW) x 7000
- E. Take the calculation from D (GW x 7000) and divide it into the number you held aside in C (above) - This is the velocity of the recoil

$$2. RE = \frac{RV^2 \times GW}{64.4}$$

Run the calculation like this:

- F. Square the recoil velocity and multiply it by the weight of the gun
- G. Divide this number (result from F) by 64.4. This is the recoil energy in ft/lbs.

Example: Actual data for .308 Winchester model 70 with 24" barrel & scope.

- PW = 40 Grains
- BW = 180 Grain sierra match king
- BV = 2,500 Fps
- GW = 8.2 lbs

$$RV = \frac{[(1.75 \times 40) + 180] \times 2,500}{7,000 \times 8.2} = \frac{625,000}{57,400} = 10.89 \text{ FPS}$$

$$RE = \frac{10.89 \times 10.89 \times 8.2}{64.4} = \frac{972}{64.4} = 15.10 \text{ ft/lbs}$$

The Recoil Velocity (RV) is 10.89 FPS

The Recoil Energy (RE) is 15.10 ft/lbs

A few pointers

- A. The weight of the gun (GW) should always be in pounds. eg. 7.3, 8.2, etc.
- B. The weight of the powder charge has a very small influence on the recoil velocity (RV) or recoil energy (RE). If you do not know the exact number, use the following guidelines:

.219 - .223	- 25 grains
.22 - 25 - .257	- 38 grains
.264 - .28	- 55 grains
.308 - 30'06	- 45 grains
.300 & 7mm mag	- 62 grains
.338	- 70 grains
.375	- 85 grains
.416 - .458	- 110 grains

Do your calculations with 2 or 3 different powder weights and you will see that the recoil energy (RE) only varies slightly. The 64.4 Number is a constant and the 7000 number is the number of grains in one pound.

The objective is to have as much compression damper travel as possible without exhausting 100% of the travel. ie., bottoming out. Too little travel or violently bottoming out can cause excessive stress to the gun and/or the rest.

With the exception of guns that are known for heavy recoil eg. 416 Rigby, .458 Winchester, etc. It is safe to start with the #2 medium damper and observe the amount of travel. Then, if necessary, change to a damper that travels the most without exhausting all of its travel. Longer damper travel means that the recoil is being dissipated over a longer time frame resulting in less stress to the gun.

A WORD ABOUT ACCURACY

When it comes to shooting, the word "accuracy" really refers to group size. Once the group is established, adjusting the sights to move the point of impact to the point of aim is a simple task. A gun/ammunition combination that shoots to 1, 3, or 5 MOA is just that. No matter what device you use to support the gun that group size will not change, not to mention extraneous factors such as sighting device, wind, stability of the shooting platform, trigger pull, parallax and/or the shooter. There is a long list of factors that can affect group size. Below we have attempted to briefly address a few of the more common ones. All comments are made with the "all things being equal" and "under perfect conditions" provisos. Please consider this a general guide that might point out a few things that might not have come to mind. Our #30013 Dangerous Game®, #30003 Precision Rifle Rests and #30088 DLX Precision Rifle Rest are designed to produce repeatable results. If the rests are properly assembled, securely anchored to a bench that is rock solid and does not shift under the stress of recoil, you will be able to maximize repeatability. Each rest will consistently repeat well under 3 MOA. What this means is that if the gun/ammunition combination is capable of shooting groups of less than 3 inches at 100 yards (nominal 3 MOA), you will be able to realize this degree of repeatability with either rest. The big word in the previous sentence is "IF". Neither rest will make a 3 MOA gun place all of the bullets in one hole. The group will still be 3 MOA. If your bullets are not all forming a tight group, there is a high probability that the problem is a result of the gun, ammunition and/or the sight.

* MOA – Minute of arc – A circle has 360°, each degree has 60 minutes, i.e. 1/60th degree. 1.0 MOA is exactly 1.047 inches at 100 yards.

CENTER FIRE ACCURACY

A large percentage of the rifles, old and new, in the hands of American sportsmen will not shoot much better than 2.5 MOA with exceptional guns shooting 1.0 – 1.5 MOA, (assuming the ammunition is correctly matched to the gun). The average deer rifle, using popular brand, off the shelf ammunition is probably capable of 2.5-3.0 MOA because the gun and ammunition manufacturers know that a typical white tail is statistically harvested at a range of less than 100 yards, and a gun that places the bullets within 3 MOA will easily place all of them within a heart sized circle. Manufacturing guns and ammunition that will shoot under 1 MOA is, of course, done every day, but there are only a few manufacturers that guarantee that result, and then only with ammunition that they specify. The costs associated with the manufacturing, quality control, and attention to detail, price these guns out of reach of a large part of the market. With that being said, a gun/ammunition combination with 3 MOA accuracy, properly sighted in, will usually get the job done and nobody will know the difference. The target is dead –end of story. The point here is that if your gun is shooting at or beyond 3 MOA, the issue is, in all probability, a combination, of factors that can affect accuracy.

We have prepared a short list of issues you may want to consider in examining the group size of your rifle.

- A. Bolt action sporting rifles are by nature and design typically more accurate than pump, lever, or semi-automatic rifles. The reason for this is the bolt action tends to be much more rigid, and therefore flexes less. In addition, a bolt action usually has a larger and stronger extraction mechanism, which means the chamber can be made to closer tolerances than other types of actions. Believe it or not, not all ammunition in the same caliber is made to the exact same dimensions by all manufacturers. For example, SAAMI (Sporting Arms and Ammunition Manufacturers Institute, www.saami.org publication ANSI/SAAMI Z299-1992) allows a variance of up to -.008 under the standard for diameter, and up to -.007 under for the standard distance from the base to the shoulder (this determines headspacing) for center fire 30-06 ammunition. (Variances across most calibers are similar.) The extraction mechanism in pump, lever, and especially in semi-automatic weapons must be able to consistently and effectively extract cartridge cases at a rate equal to the cyclic rate of the weapon using the entire range of commercially available ammunition. This can be problematic if the cartridge fits too tight in the chamber. As a result manufacturers tend to make these chambers more tolerant of ammunition that may tend towards the larger end of the size range. Conversely, if ammunition manufacturers want their product to function in guns typically in the hands of sportsmen, they must also consider how easily the cartridge seats and extracts. Needless to say, there are exceptions to this, but as a rule as you move away from a precise cartridge chamber fit accuracy suffers. This is especially apparent in military weapons because they must chamber ammunition from various sources (therefore with various tolerances) and must function even if the ammunition is corroded or dirty. Reliability, not pinpoint accuracy is the primary criteria.
- B. Match the correct bullet weight to the twist of the rifling. This is one of the most commonly overlooked factors that determines group size. If the bullet length and twist rate of the barrel are not synchronized, accuracy will suffer. A 110 grain .308 bullet is, of necessity, shorter than a 220 grain .308 bullet. For proper stabilization the heavier, and hence longer bullet, requires a faster rate of rifling twist than a short, light bullet. Further to this point, different guns respond differently to ammunition from different manufacturers. The point here is that you should test fire ammunition from several manufacturers and select bullet weights that are compatible with the rate of twist of the gun's rifling. Generally speaking, twist rate is stamped on the barrel or the information is available from the manufacturer. You need to test different bullet weights to optimize results.) The following websites will give you more information regarding this issue:
www.snipercountry.com/hotlips/twistrate.html
www.uslink.net
kwk.us/twist.html
en.wikipedia.org/wiki/rifling
www.gsgroup.co.za/cip.html

Calculating Twist Rate

Legend:

BL = Bullet Length

BD = Bullet Diameter

C = 150 constant for muzzle velocity 1500-2800 FPS

C = 180 constant for muzzle velocity over 2800 FPS

(choose the correct constant for the ammunition you are using)

Formula:

$$\frac{C}{\frac{BL}{BD}} \times BD$$

First divide the bullet diameter (for example .224) into the bullet length (for example .712). Divide the result into the correct constant (150 or 180) and multiply the result by the BD (for example .224). The result is the **approximate minimum** twist rate necessary to stabilize the bullet - Remember a 1:9 rate is faster than a 1:14 rate.

Example A: .223 (5.56 x 45) @ 3200 FPS, 52 Grain, BL = .712 BD = .224

$$\frac{180}{\frac{.712}{.224}} = \frac{180}{3.178} = 56.64 \times BD = 56.64 \times .224 = 12.7$$

12.7 is the optimum rate of twist

Example B: .223 (5.56 x 45) @ 2500 FPS, 75 Grain, BL = 1.095 BD = .224

$$\frac{150}{\frac{1.095}{.224}} = \frac{150}{4.9} = 30.6 \times BD = 30.6 \times .224 = 6.86$$

6.9 is the optimum rate of twist

If you use the 52 grain bullets in a 7.0 twist barrel the result will be fairly accurate. If you use the 75 grain bullet in a 12.0 or 13.0 twist barrel your group will probably be all over the target.

Diameters of Popular Bullets

.204 - .204 7mm - .284.

.223 - .224 .308 - .308

.243 - .243 .338 - .338

.270 - .277 .375 - .375

Bullet length varies by manufacturer and style. For this information check with the manufacturer or take an actual measurement.

C. A perfectly formed muzzle crown allows the gas to escape in a uniform pattern around the base of the bullet as it exits. Through improper cleaning and handling the crown of the muzzle can be easily damaged. Even a small ding, which may not necessarily be visible to the naked eye, can cause an uneven release of gas, which can heel the bullet over slightly, producing a yaw attitude. This will affect the bullet's stability and accuracy, as the long axis of the bullet will no longer be coincidental with the path of travel.

D. The quality of the ammunition you use can have a direct result on repeatable group size; the more consistent the ammunition, and the components from which it is manufactured, the more consistent the results. Several manufacturers make match grade ammunition where the components are carefully selected and screened for consistency and conformance to specification. (One of the manufacturers that are best known for achieving the most consistent results is Black Hills www.black-hills.com). There are several other manufacturers that make acceptable match grade ammunition, and there are other options. If you are a re-loader, you are already aware of the range of quality components available and in all probability you are able to produce consistent, high quality ammunition.

E. Vertical Grouping – See Rim Fire section point D.

- F. Check Your Scope and Mounting – With older and especially inexpensive scopes it is not uncommon for the reticle to stick or shift, especially under heavy recoil and/or temperature extremes. If this happens your muzzle could end up pointing in a slightly different direction after each shot. To check for this condition, lock the gun in a vise that doesn't move and sight the reticle on a set point/target then use a piece of wood or other object (that will not do damage), to tap the scope tube to imitate recoil. If the reticle moves from the original point of aim, you have a problem with the scope. Also check the scope mounting using the same procedure. Mounts and rings frequently become loose due to recoil and heat. In addition to properly mounting a scope the rings must be lapped and centered other wise there may not be sufficient contact to secure the scope. Even Locktite doesn't insure that mounts and rings will not shift.
- G. Parallax is the apparent shift of the target relative to the reticle due to the horizontal movement of the observer. Scopes with parallax adjustments must be correctly adjusted. Scopes without a parallax adjustment are generally range specific for parallax free sighting. If you have made the adjustments to eliminate parallax you are good to go. If not, it is important to make sure that the longitudinal optical axis of the scope that runs through the center of the crosshairs is directly aligned with the pupil of your eye. If you have an inconsistent cheek weld to your stock or fail in any other way to address parallax your groups will suffer from horizontal dispersion, i.e.:open up left to right. This will happen because your view of the target in the horizontal plane will vary with each shot.
- H. Barrel temperature plays a major role in maintaining group size. As a barrel heats up torsional stress will cause the barrel to twist. Bench rest shooters wait several minutes between each shot to keep the barrel from overheating. If you fire 10 or 12 shots in rapid succession from a sporter weight barrel your groups will expand.
- I. Other factors, which we will not explore here include: Free floating barrels, bedding, barrel harmonics, etc. - Not to mention the shooter!

RIM FIRE ACCURACY

(Some of this applies to center fire rifles also.)

Accuracy in a rim fire rifle is to a large degree more dependent upon the ammunition as opposed to the equipment. Center fire ammunition can be loaded and/or reloaded to precise and consistent specifications. Rim fire ammunition can only be loaded at the factory level. Since rim fire ammunition is not re-loadable, it is necessary to use whatever is commercially available. Factors affecting rim fire accuracy are:

- A. As with a center fire cartridge there is a SAAMI specification (ANSI/SAAMI Z 299.1-1992) and variance for the dimensional aspects of rim fire ammunition that allows up to -.004 under the standard diameter for .22 long rifle match or sporting ammunition. Consequently, manufacturers make ammunition within the entire range of this variance. As a direct result a gun that is expected to perform reliably must be able to accept the full range of available ammunition. What this has led to are guns that are match chambered which are invariably bolt action. (The chambers in these guns have a tight precise cartridge fit and the guns perform best with match grade ammunition that is made to close tolerance), and then we have most other guns that have sporting chambers, many of which are auto loaders. The chambers in these guns must be made large enough so that the gun will cycle correctly with any off the shelf brand of ammunition which could be manufactured to any size within the allowable range of tolerance. i.e., This means the cartridge may fit loosely in the chamber. Due to gravity the cartridge settles into the lowest portion of the chamber. The result is that the center axis of the chamber, and hence the center axis of the barrel is not aligned with the center axis of the bullet. This means that the bullet will engage the rifling off center and will travel down the barrel and exit the muzzle at an angle resulting in a loss of stability and accuracy.
- B. Concentricity – If the long axis of the bullet is not concentric with the long axis of the case it will also not be concentric with the long axis of the bore, as above the bullet will travel down the barrel and exit the muzzle at an angle with similar results. As little as .002”–.003” off center will cause a noticeable enlargement of the grouping.

- C. Head Spacing is the distance the bullet must move from the casing until it engages the rifling. In a rim fire this is controlled by the thickness of the rim. According to SAAMI standards rim thicknesses may vary from as little as .036" to as much as .043". A gun may perform much better with one rim thickness as opposed to others. It is therefore important to test your gun with a wide range of ammunition. Typically in a box of inexpensive ammunition you will find a considerable variance in rim thicknesses. This will usually result in expanding the group size; consistency of rim thickness will result in smaller, consistent group sizes. Both concentricity and rim thickness can be measured by using the HYSKORE® #30075 Ammo Analyzer.
- D. If the group spread is more vertical than horizontal it is usually the fault of the ammunition. At a known distance, a faster bullet reaches the target quicker and drops less, i.e. gravity has less time to act. As you may appreciate, the small quantities of primer and propellant used in a rim fire cartridge must be precisely and accurately measured in order to produce consistent velocity. Only a small variance in absolute terms translates to a significant percentage variation and by extension, variation in velocity. Maintaining this type of consistency across large production runs is incompatible with maintaining low cost. Primer compound has an explosive force in the magnitude of 25 to 50 times that of the propellant. As little as 1/10 grain (1/70,000 lb.) deviation will cause a velocity differential. With these thoughts in mind, the culprit in groups that open top to bottom is almost always inconsistent velocity. The faster bullets strike higher and the slower ones lower.
- E. Scope Problems – See "F" and "G" under Center Fire.

The aforementioned issues represent a brief synopsis of various conditions that may affect accuracy. There are numerous in depth studies that can provide detailed analysis of each situation. We are not experts and do not intend to be. Our comments and suggestions are the result of studying and compiling data from a wide range of sources. Furthermore, we have only touched on the more significant factors that affect accuracy. If you elect to make adjustments to your gun/ammunition combination to increase accuracy, we suggest that you address each issue one at a time. Do not try to make multiple corrections at the same time as you may contaminate the results, and possibly obscure important issues that need further attention.

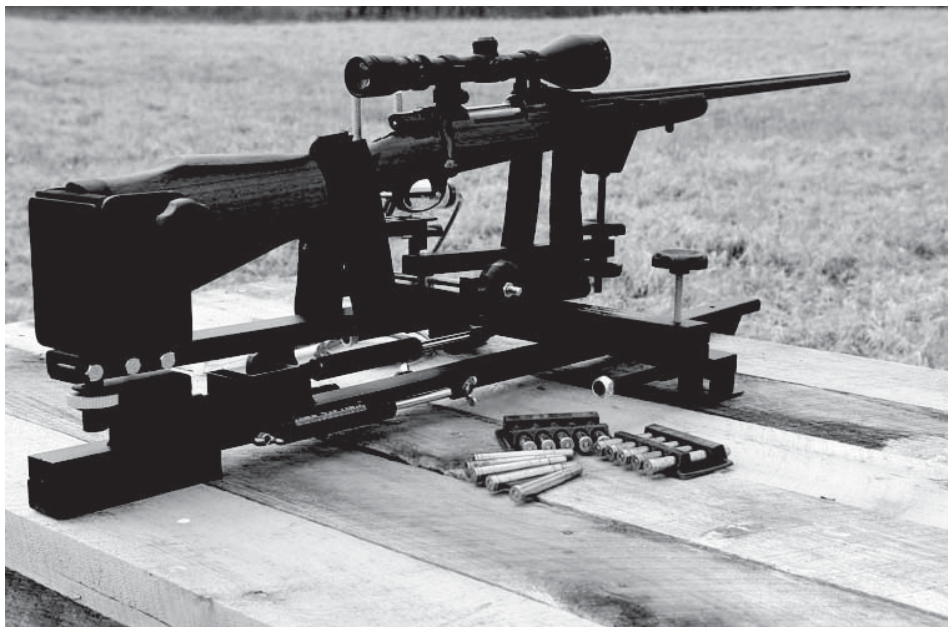

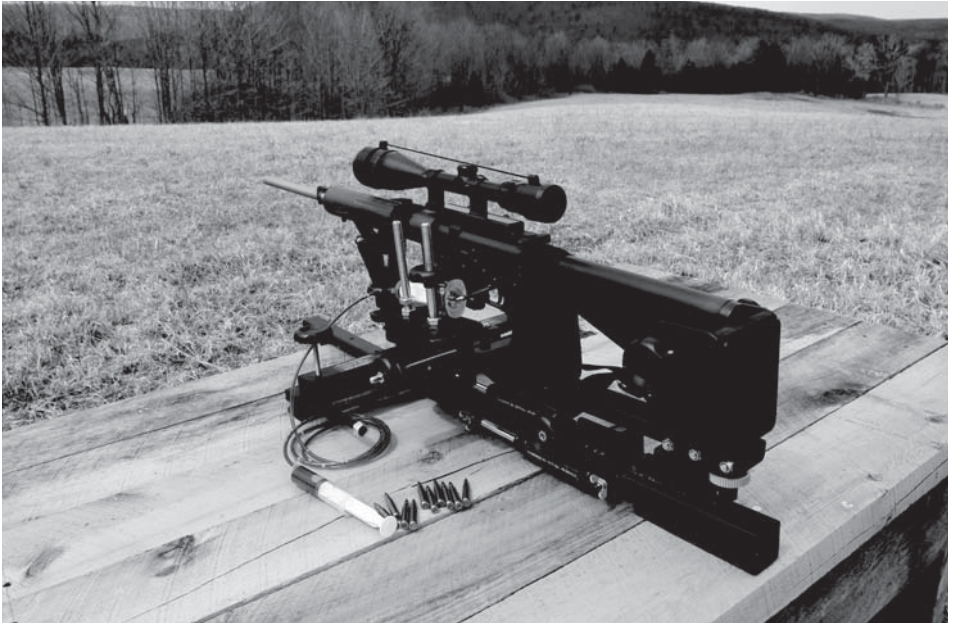

AR-15 .223

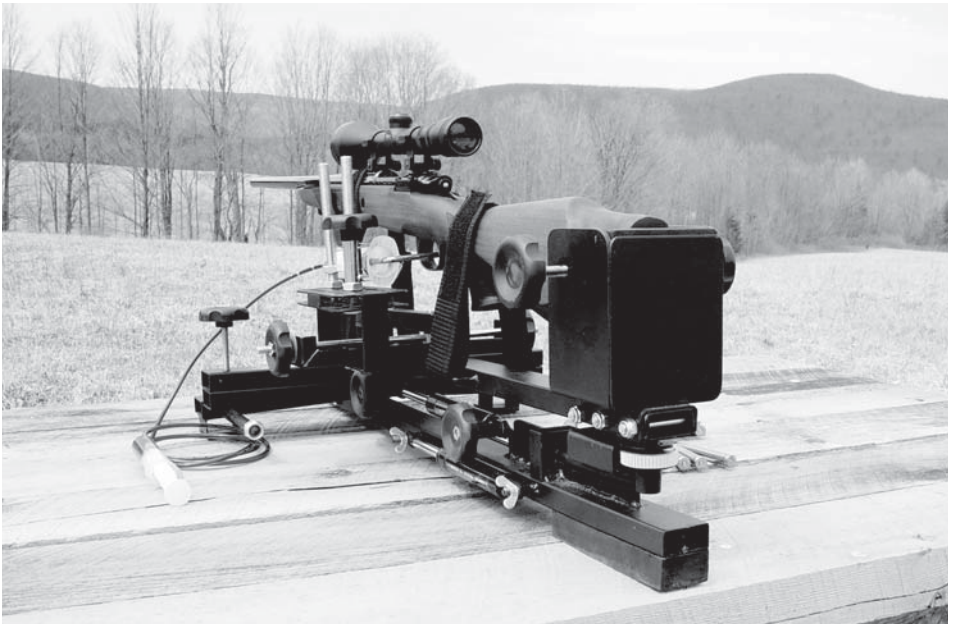

CZ-550 .375 H&H

Parts List & Pricing:

30013 - 1	Gas Damper MILD 3 - 20 FT/Lbs.	\$ 37.50
30013 - 2	Gas Damper MEDIUM 15 - 60 FT/Lbs.	\$ 37.50
30013 - 3	Gas Damper HEAVY 55 - 90 FT/Lbs.	\$ 37.50
30013 - 4	Bench Grip Arm	\$ 27.50
30013 - 5	Velcro Straps (2)	\$ 22.50
30013 - 6	Stock Vise Set	\$ 37.50
30013 - 7	"V" Notch Support Set	\$ 25.00
30013 - 8	Base	\$ 65.00
30013 - 9	Carrier Assembly	\$ 75.00
30013 - 10	Windage Set	\$ 27.50
30013 - 11	Cant Adjusters & Glide Bar Set	\$ 45.00
30013 - 12	Hydraulic Trigger Release Set	\$ 37.50
30013 - 13	Trigger Release Bracket Set	\$ 27.50
30013 - 14	Gas Damper Hardware Set	\$ 19.00
30013 - 15	Pad & Cushion Set	\$ 15.00
30013 - 16	Fine Elevation Assembly	\$ 22.50
30013 - 17	Base Pad Set	\$ 5.00

These are replacement parts for purchase. Pictures do not represent contents of set.
Visit Our Website For More Information or to Check Out Our Other Great
Shooting Accessories: www.hyskore.com

Send Check or Money Order
with Phone Number to:

Hyskore® / Power Aisle, Inc.

193 West Hills Rd.

Huntington Station NY, 11746

NYS Resident add 8.625% Sales Tax

(Or Prevailing Rate)

** \$10.00 Shipping & Handling to
Lower 48 States**

** \$25.00 Shipping & Handling to
Alaska, Hawaii, Puerto Rico**

WARRANTY AND DISCLAIMERS

HYSKORE®/Power Aisle, Inc. guarantees that its products are free from defects in material and workmanship for a period of 1 year (12 months) from the original date of purchase. This Warranty applies to non-commercial use only. Commercial use voids this warranty. In the event of any defects in material or workmanship, HYSKORE®/Power Aisle, Inc.'s sole liability therefore shall be the replacement of any such product(s) and/or components that are defective in material or workmanship. The replacement of any such product(s) and/or components shall be HYSKORE®/Power Aisle, Inc.'s sole responsibility. This warranty specifically excludes any and all consequential or accidental damages. No other warranties or liabilities whatsoever are either expressed or implied. If any such warranties shall be imposed by law, notwithstanding this provision, then such warranties shall be the responsibility of HYSKORE®/Power Aisle, Inc.'s immediate buyer. There shall be no warranties of merchantability, use of trade, or fitness for a particular purpose. Alteration of any product, misuse, or exceeding any stated product limitations voids this warranty. All returns, adjustments, etc. are the responsibility of the retailer/dealer that sold the product. HYSKORE®/Power Aisle, Inc. handles return issues through its dealers. It should be obvious when using some of these products that approved protective safety gear, including, but not limited to, eye and ear protection, should be utilized. Using the appropriate safety gear is the sole responsibility of the person(s) using the product. It should also be obvious that certain products such as silica gel, etc. must not be consumed, inhaled or taken internally. The user takes full responsibility for inappropriate or incorrect use of these items. In the event an inadvertent event takes place, Material Safety Data Sheets (MSDS) are available on the HYSKORE® website. www.hyskore.com. We do not sell guns, scopes, ammunition, cleaning accessories, etc. These accessories are used in many of our product pictures, as props to illustrate how the products are used. As such, they are not included with any product. All photographs, drawings, copy, instructions, etc. are the exclusive property of HYSKORE®/Power Aisle, Inc. All downloadable files are intended for the use of the end user of HYSKORE®/Power Aisle, Inc.'s products and cannot be reproduced without the express written permission of HYSKORE®/Power Aisle, Inc.

• REPLACEMENT PARTS •

30013 - 1

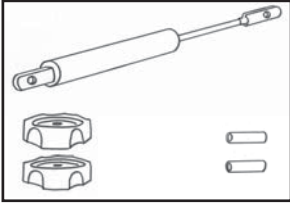

30013 - 2

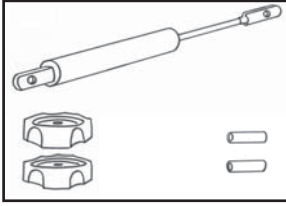

30013 - 3

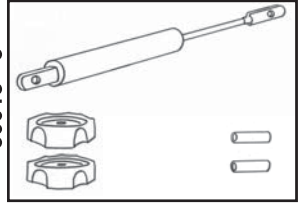

30013 - 4

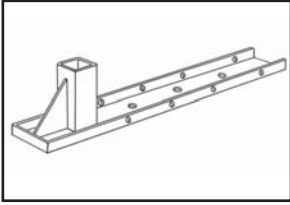

30013 - 5

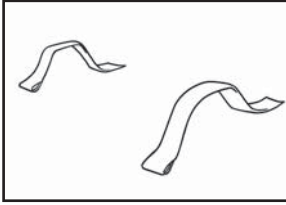

30013 - 6

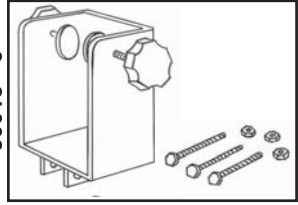

30013 - 7

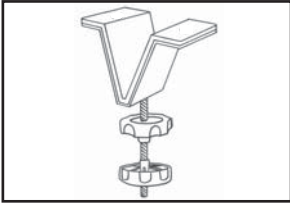

30013 - 8

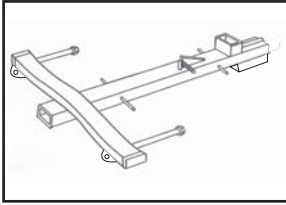

30013 - 9

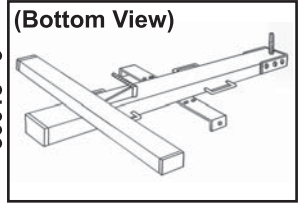

30013 - 10

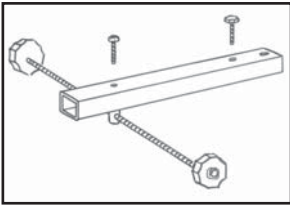

30013 - 11

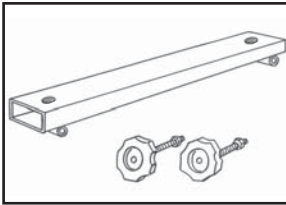

30013 - 12

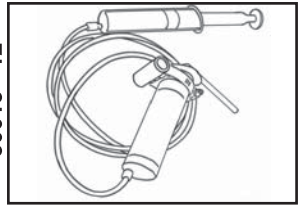

30013 - 13

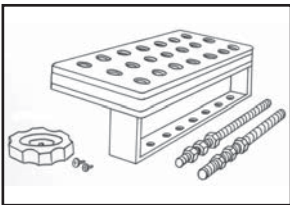

30013 - 14

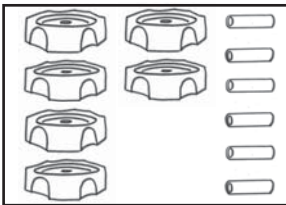

30013 - 15

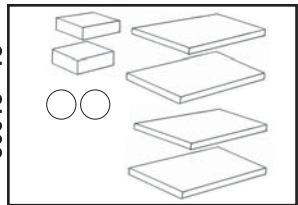

30013 - 16

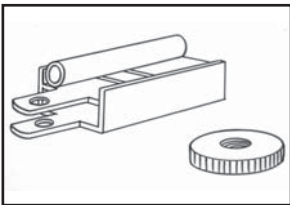

30013 - 17

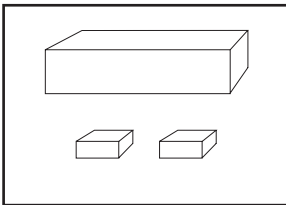

50 BMG Armarlite AR 50 mounted in the

#30013 Hyskore® Dangerous Game® Machine Rest



For parts or technical support contact:

Hyskore®

Power Aisle, Inc.

193 West Hills Road • Huntington Station, NY • 11746

Phone: 631.673.5975 • Fax: 631.673.5976

visit us @ www.hyskore.com